

TECHNICAL DRAWING

DELIVERY REQUEST FORM

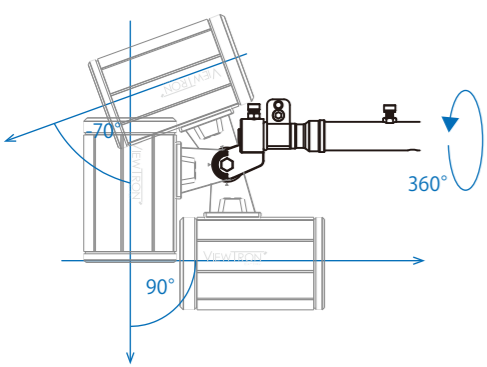

TO PREVENT WATER FROM ENTERING THE DEVICE, PLEASE USE IT WITH AN UP/DOWN OR LEFT/RIGHT TILT ANGLE OF AT LEAST 10° FROM THE VERTICAL POSITION.
EACH MARK ON THE ADJUSTMENT KNOB CORRESPONDS TO 10°. IN ADDITION, IN AREAS WITH HEAVY SNOW, WHEN ILLUMINATING UPWARD, ADJUST THE ANGLE SO THAT THE LIGHT-EMITTING SURFACE IS NOT COVERED BY SNOW.

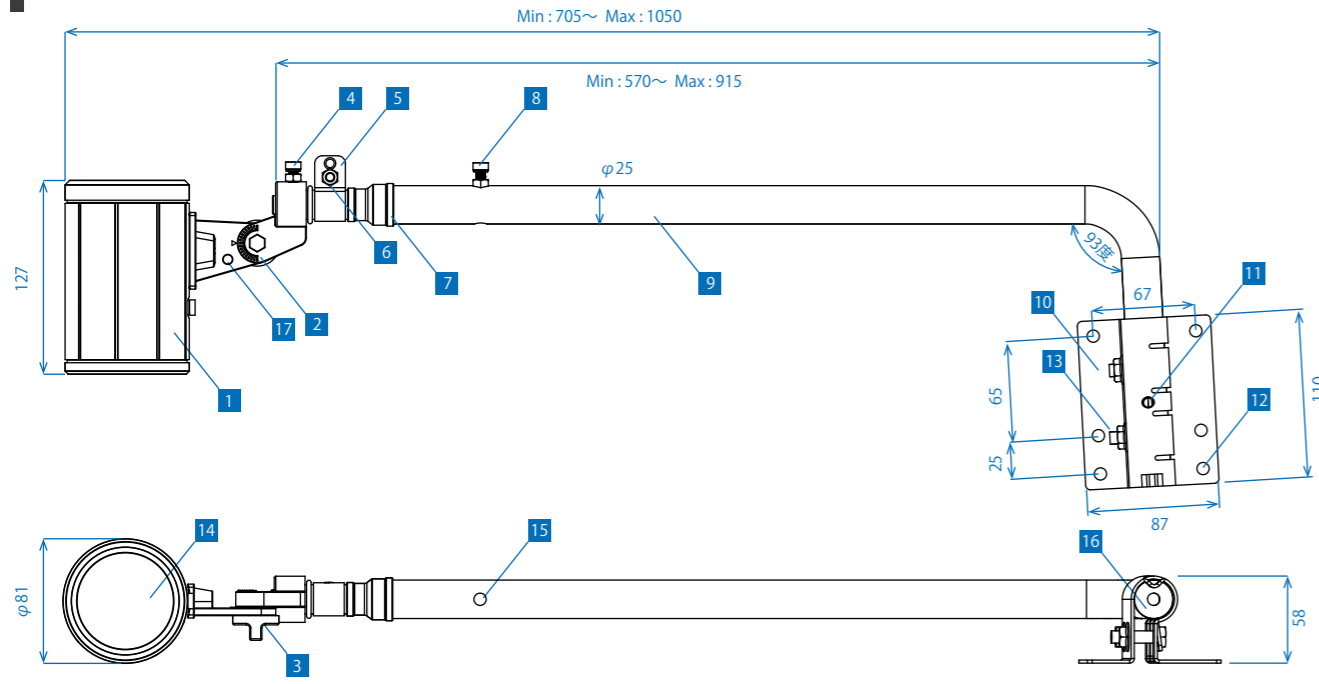
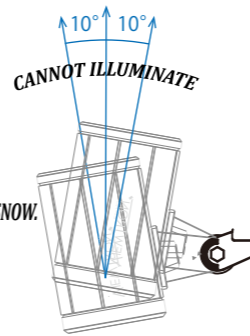

PARTS LIST TABLE

PART NAME	MATERIAL	REMARKS	QUANTITY
1 LAMP	DIE-CAST ALUMINUM	POWDER COATING	1
2 ANGLE ADJUSTMENT SCALE	-	-	-
3 KNOB	DIE-CAST ALUMINUM	POWDER COATING	1
4 ROTATION ADJUSTMENT BOLT	SUS	M6 HEX SOCKET BOLT	1
5 CABLE CLAMP	SUS	POWDER COATING	1
6 CABLE CLAMP BOLT	SUS	M6 HEX SOCKET BOLT	1
7 WATERPROOF GASKET FOR ARM	SILICON	M6 HEX SOCKET BOLT	1
8 TELESCOPIC ARM FIXING BOLT	SUS	-	1
9 L-SHAPED ARM PIPE	SUS	POWDER COATING	1
10 MOUNTING PLATE	SUS	POWDER COATING	1
11 ARM ORIENTATION FIXING BOLT	SUS	M6 HEX SOCKET BOLT	1
12 MOUNTING PLATE FIXING HOLE	-	HOLE DIAMETER 8MM	6
13 MOUNTING PLATE NUT	SUS	-	2
14 LIGHT-EMITTING SURFACE COVER	PC	120°: MILKY WHITE / 40°: CLEAR	1
15 DRAIN HOLE	-	-	1
16 CABLE PROTECTION TUBE	SILICON	GRAY	1
17 LAMP CABLE HOLE	-	-	1

TECHNICAL SPECIFICATIONS TABLE

DESIGN	VT20-120C-L(/BK)	VT20-120W-L(/BK)	VT20-40C-L	VT20-40W-L
EQUIVALENT BRIGHTNESS	160W COMPATIBLE LAMP			
BODY COLOR	WHITE	BASIC MODEL / BLACK (BK)	WHITE	BASIC MODEL / BLACK (BK)
POWER CONSUMPTION	14W			
LIGHT DISTRIBUTION ANGLE	120°		40°	
LIGHT COLOR	DAYLIGHT 6,000K	WARM LIGHT 2,700K	DAYLIGHT 6,000K	WARM LIGHT 2,700K
TOTAL LUMINOUS FLUX	1,480lm	1,400lm	1,580lm	1,520lm
CURRENT VALUE	100V:0.14A / 200V:0.07A			
WEIGHT	2.1kg (包含 附件 重量)			
INPUT VOLTAGE	AC100V~240V ±10% (50/60Hz)			
COLOR RENDERING INDEX	> 80Ra			
PROTECTION CLASS	IP65			
POWER FACTOR	> 0.9			
DESIGNED LIFESPAN	40,000 HOURS (AT AMBIENT TEMPERATURE 25°C)			
OPERATING TEMPERATURE	-20°C TO 50°C, HUMIDITY BELOW 90%			
DUST AND WATER RESISTANCE	3750V (COMMON MODE)			
OUTPUT CABLE LENGTH	OUTSIDE DIMENSION: MIN 520MM ~ MAX 870MM (ADJUSTABLE)			
CERTIFICATION TESTS	PSE (ELECTRICAL SAFETY LAW), VIBRATION TEST (IEC60068-2-6) SALT SPRAY CORROSION TEST (ISO9227), WATERPROOF & DUSTPROOF TEST (IP65)			
PRODUCT WARRANTY	2 YEARS			
ACCESSORIES INCLUDED	USER MANUAL, FALL PREVENTION WIRE (3M), HEX KEY			

SIZE
A4

PRODUCT
NAME

VIEWTRON VT20 L-ARM SET

VT20-L-001

NIKKEN HARDWARE

□ VT20-120C-L(/BK) □ VT20-120W-L(/BK) □ VT20-40C-L □ VT20-40W-L

FOR STORAGE PURPOSES.

PLEASE HAND THIS USER MANUAL TO THE USER.



OUTDOOR INTEGRATED ARM LED LIGHT VIEWTRON VT20 L ARM SET

※ WIRING AND INSTALLATION OF THE LIGHT MUST BE PERFORMED BY A CERTIFIED ELECTRICAL CONTRACTOR. UNAUTHORIZED PERSONS ARE PROHIBITED BY LAW FROM CARRYING OUT ELECTRICAL WORK.



CUSTOMER

DO NOT USE IN THE FOLLOWING CONDITIONS (RISK OF FIRE, ELECTRIC SHOCK, OR DAMAGE):

Exceeding allowable temperature/humidity
Strong vibration or impact
Presence of corrosive or flammable gas
Areas with heavy oil vapor
Submerged in water
In contact with flammable materials

FOLLOW THE INSTALLATION INSTRUCTIONS EXACTLY. DO NOT MODIFY OR SUBSTITUTE PARTS.

CONNECT THE POWER SUPPLY PROPERLY TO PREVENT FIRE OR ELECTRIC SHOCK.

DO NOT COVER THE DEVICE (WITH GRASS, PLANTS, INSULATION MATERIALS, ETC.). THIS MAY CAUSE FIRE.

THE DEVICE BECOMES HOT DURING OPERATION. AVOID TOUCHING TO PREVENT BURNS.

INSTALL SECURELY IN A LOCATION THAT CAN WITHSTAND WEIGHT, WIND, AND VIBRATION TO PREVENT FALLING, FIRE, OR ELECTRIC SHOCK.

THIS PRODUCT MAY INVOLVE WORKING AT HEIGHTS. BEFORE INSTALLATION, POWER IT ON TO CHECK FOR ORDER ERRORS, WRONG PRODUCTS, OR DAMAGE.



CAUTION

PRECAUTIONS FOR INSTALLATION:

Use only in normal indoor/outdoor environments.
Ensure the mounting surface is strong, free from rust, and not corroded.
Ensure the installation does not cause light pollution.
Maintain a safe lighting distance — at least 0.15 m to prevent fire hazards.

USE RUBBER-INSULATED ELECTRIC WIRE RNCT 0.75 mm² OR LARGER.

DO NOT CONNECT TO A DIMMER SWITCH (BRIGHTNESS CONTROL). THIS MAY CAUSE MALFUNCTION.

DAMAGE CAUSED BY LIGHTNING IS NOT COVERED BY WARRANTY. INSTALL A LIGHTNING PROTECTION DEVICE IN THE CIRCUIT.

DO NOT USE THE PRODUCT CONTINUOUSLY FOR 24 HOURS. THIS WILL REDUCE THE PRODUCT'S LIFESPAN.

WARNING

PRODUCT LIFESPAN

THE LIFESPAN OF LEDS DEPENDS HEAVILY ON AMBIENT TEMPERATURE.
THE DESIGNED LIFESPAN OF 40,000 HOURS IS BASED ON AN AMBIENT TEMPERATURE ≤ 25°C.
ENVIRONMENTS WITH OIL VAPOR, HIGH HUMIDITY, NEAR KITCHENS, OR UNDER STRONG SUMMER SUNLIGHT CAN SIGNIFICANTLY REDUCE THE LIFESPAN.

OPERATING TIME

IF USED FOR MORE THAN 20 HOURS PER DAY, THE LIFESPAN WILL BE GREATLY REDUCED AND THE WARRANTY PERIOD WILL BE HALVED.

CLEANING

OIL, DUST, AND WOOD CHIPS ACCUMULATED ON THE LAMP MAY PREVENT EFFECTIVE HEAT DISSIPATION AND CAUSE DAMAGE.
CLEAN REGULARLY BY WIPING DRY OR USING DILUTED NEUTRAL DETERGENT.

LIGHTNING PROTECTION

THE DEVICE CAN WITHSTAND SURGE VOLTAGE UP TO 3750V, BUT LEDS ARE MORE SENSITIVE TO LIGHTNING THAN INCANDESCENT OR MERCURY LAMPS.
DAMAGE CAUSED BY LIGHTNING IS NOT COVERED BY WARRANTY.
CONSULT AN INSTALLER TO ADD A LIGHTNING PROTECTION DEVICE TO THE ELECTRICAL CIRCUIT.

NIKKEN
HARDWARE

1 CHECK BEFORE INSTALLATION

※ VÌ LÀ SẢN PHẨM DÙNG Ở NƠI CAO, HÃY NHẤT ĐỊNH KIỂM TRA TRƯỚC KHI THI CÔNG, KHÔNG PHẢI TRONG QUÁ TRÌNH THI CÔNG.

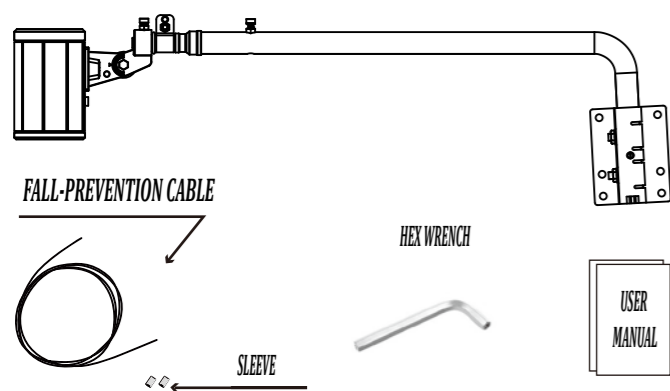

- CHECK IF THE LIGHT DOES NOT TURN ON
- ※ USER MANUAL (THIS BOOK) x1
- ※ HEX WRENCHES (2 PCS) x1
- ※ CABLE (WIRE THREE) x2
- ※ FALL-PREVENTION CABLE (3M) FOR ARM AND INSTALLATION PLATE (L) x1
- ※ MAIN EQUIPMENT (LIGHT) x1

- CHECK CONTENTS
- ※ CONFIRM THAT ALL COMPONENTS AND ACCESSORIES ARE INCLUDED.
- OTHERS
- CONNECT THE ELECTRICAL WIRES FROM THE OUTPUT AND CHECK THAT THE LIGHT TURNS ON.

2 INSTALLATION NOTES

INSTALL SO THAT THE OUTPUT WIRE FACES DOWNWARD TO PREVENT RAINWATER FROM ENTERING THE ARM.
(1) AS SHOWN BELOW, INSTALL THE ARM ON A VERTICAL PLANE.

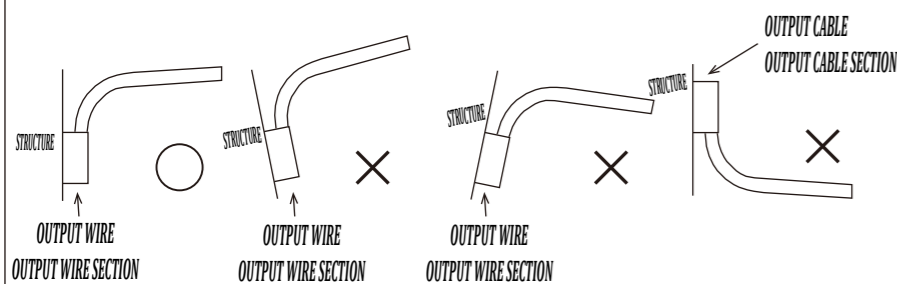

THE LOWER ARM CAN BE FIXED AT ANY POSITION WITHIN 360°.
IN TOTAL, THERE ARE 4 POSSIBLE ORIENTATIONS: UPWARD, DOWNWARD, 9° TO THE RIGHT, 9° TO THE LEFT.
ACCORDING TO ITEM (2), THE ARM SHOULD NOT BE INSTALLED FACING THE FRONT.

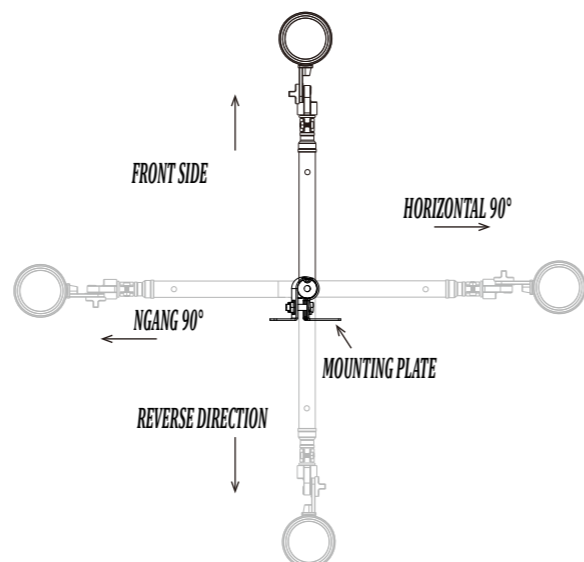

3 FIX THE MOUNTING PLATE



REMOVE THE ARM ORIENTATION FIXING BOLT, AND LOOSEN THE TWO MOUNTING PLATE NUTS AT (1).

INSTALL IN A SECURE LOCATION THAT CAN SUPPORT THE WEIGHT OF THE PRODUCT, SUCH AS A SIGN OR BUILDING STRUCTURE.
USE M6 OR M7 BOLTS AND THE Ø8 FIXING HOLES ON THE MOUNTING PLATE TO SECURE THE PLATE.

4-1 FIX THE ARM TO THE MOUNTING PLATE (WHEN INSTALLING ON A WALL, ETC.)

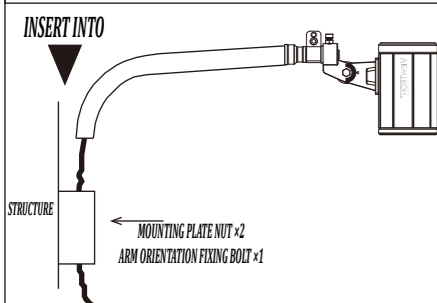

FIX THE LOWER ARM TO THE MOUNTING PLATE.
USE BOLTS TO SECURE THE ARM ORIENTATION AND NUTS TO TIGHTEN THE MOUNTING PLATE, ENSURING THE CABLE IS PROTECTED.
INSERT HEX BOLTS INTO THE BUSHES IN THE MOUNTING PLATE, THEN PUSH FULLY UNTIL THE BUSH TOUCHES THE STOPPER INSIDE THE MOUNTING PLATE.
NEXT, INSERT THE ARM INTO THE MOUNTING PLATE, AND ACCORDING TO ITEM (2), DETERMINE THE DESIRED ARM ORIENTATION FOR INSTALLATION.

4-2 FIX THE ARM TO THE MOUNTING PLATE (WHEN INSTALLING ON THE TOP OF THE SIGN, ETC.)

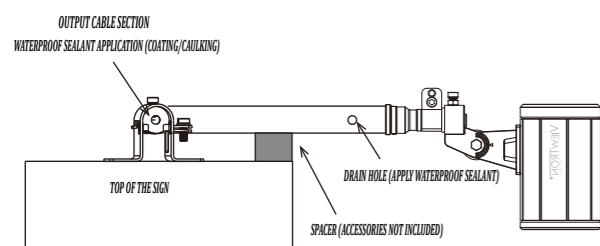

INSTALL AS SHOWN BELOW, IN COMBINATION WITH ITEM (4)-1.
SINCE THE DRAIN HOLE FACES HORIZONTALLY, ENSURE THAT RAINWATER OR OTHER LIQUIDS DO NOT ENTER THE INSIDE OF THE ARM TUBE BY APPLYING WATERPROOF SEALANT AT THE DRAIN HOLE.
SIMILARLY, APPLY WATERPROOF SEALANT TO THE OUTPUT CABLE SECTION.
AT LOCATIONS SUBJECT TO WIND LOAD OR VIBRATION, INSERT A SPACER OR SIMILAR MATERIAL BETWEEN THE TOP OF THE SIGN AND THE ARM TO DISTRIBUTE THE LOAD.
ENSURE THERE ARE NO GAPS BETWEEN THE ARM AND THE SPACER, THE ARM RESTS ON THE SPACER, AND ADJUST THE SPACER HEIGHT TO EVENLY DISTRIBUTE THE WEIGHT.

5 ADJUST THE LENGTH OF ARM L

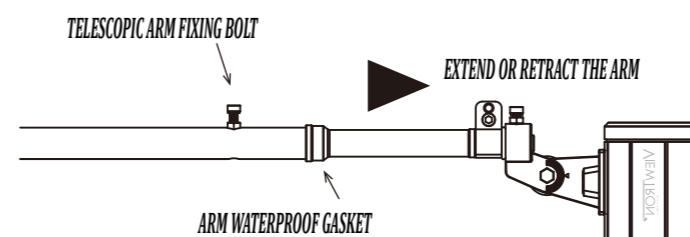

ADJUST THE POSITION OF THE WATERPROOF GASKET TO COVER THE ARM JOINT.
THE AREA CAN BE EXTENDED OR RETRACTED FOR REFERENCE ON THE REAR VIEW DRAWING.
TIGHTEN TO SECURE.
AFTER ADJUSTING THE ARM LENGTH TO ENSURE PROPER PROTRUSION, USE THE FIXING BOLT TO SECURE THE RETRACTABLE ARM (1).
WHEN LOOSENING THE FIXING BOLT OF THE RETRACTABLE ARM, THE ARM CAN BE PULLED OUT OR RETRACTED.

6 ADJUST THE LIGHTING DIRECTION OF THE LIGHT

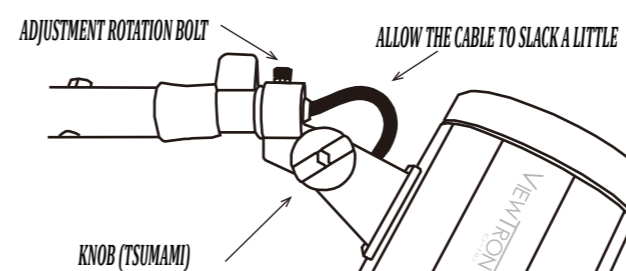

(1) LOOSEN THE KNOB AT THE BASE OF THE LAMP TO ADJUST THE VERTICAL LIGHT DIRECTION.
CHECK THAT THE LOCKNUT IS SECURELY FASTENED.
EVEN IF THE ROTATION ADJUSTMENT BOLT IS NOT LOOSENED, MAKE SURE THE BOLT IS SECURE.
AFTER ADJUSTING, USE THE PROVIDED HEX WRENCH TO TIGHTEN AND SECURE WITH THE LOCKNUT.

(2) LOOSEN THE ADJUSTMENT BOLT TO ROTATE AND ADJUST THE HORIZONTAL WATER DISTRIBUTION DIRECTION.
AFTER ADJUSTING THE ANGLE, TO PREVENT THE CABLE FROM BEING STRETCHED, ALLOW THE CABLE TO SLACK A LITTLE AS SHOWN IN THE LEFT PICTURE.
USE THE HEXAGONAL HOLE IN THE CENTER OF THE KNOB ALONG WITH THE SUPPLIED HEX WRENCH FOR A MORE SECURE FIXATION.
ADJUST TO THE DESIRED DIRECTION AND TIGHTEN TO FIX IN PLACE.

7 CONNECT THE POWER CABLE

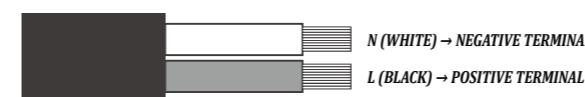

ENSURE ELECTRICAL CONNECTIONS ARE SECURE AND FIRMLY FIXED.
PLEASE REFER TO THE LEFT PICTURE TO IDENTIFY THE POLARITY.
CONNECT THE OUTPUT WIRE TO THE POWER CABLE, USING A SLEEVE, SELF-FUSING TAPE, ELECTRICAL INSULATION TAPE, OR OTHER SIMILAR MATERIALS FOR INSULATION.

8 CABLE INSTALLATION

PLEASE REFER TO FIGURE 4 AND ENSURE SECURE INSTALLATION.
WHEN FOLLOWING FIGURE 1A AND THE INSTRUCTIONS BELOW, THE PRODUCT WILL ACHIEVE THE DESCRIBED PERFORMANCE.
IT IS POSSIBLE TO INSTALL UP TO G100K AT ONCE.

CABLES (WIRE SLEEVE)
USE A RING SLEEVE CRIMPING PLIER TO SECURELY CRIMP THE WIRE SLEEVES, ENSURING HIGH TENSILE STRENGTH.
FOLLOWING THE INSTRUCTIONS BELOW WILL REINFORCE THE ARMS AND PREVENT THE LIGHT FROM FALLING.
THE PRODUCT COMES EQUIPPED WITH PRE-INSTALLED CABLE CLIPS, CABLES, AND WIRE SLEEVES.

PLEASE REFER TO FIGURES 1 TO 4 TO SEE HOW TO ROUTE THE CABLE IN A FIGURE-8 PATTERN THROUGH THE ARM AND LIGHT.

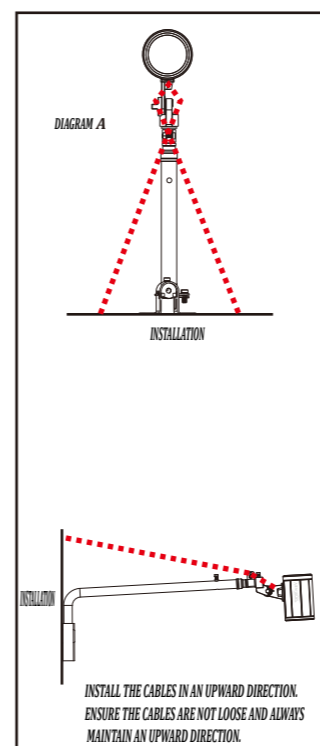
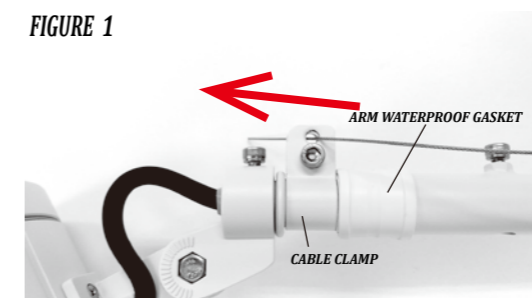

FIGURE 1



(1) THREAD THE CABLE THROUGH THE HOLE IN THE CABLE CLIP, FROM FRONT TO BACK.

FIGURE 2



(2) THREAD THE CABLE THROUGH THE HOLE ON THE LIGHT, THEN PULL THE CABLE BACK FROM THE REAR TO THE FRONT.

FIGURE 3

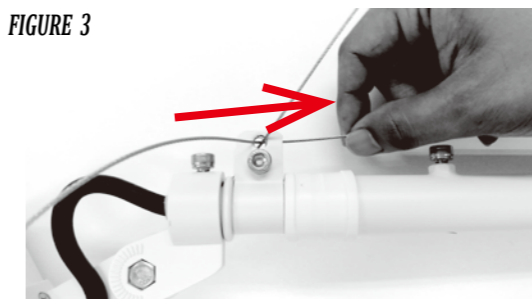

INSERT THE CABLE.
(3) THREAD IT THROUGH THE HOLE IN THE CABLE CLIP.
ROUTE FROM THE FRONT TO THE BACK.

FIGURE 4

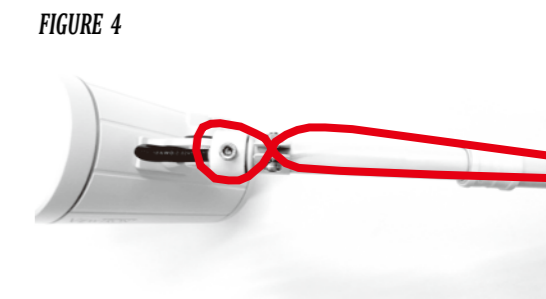

CHECK THE CABLE FIXING BOLT TO ENSURE IT IS NOT LOOSE.
WHEN VIEWED FROM ABOVE, THE CABLE SHOULD LIE IN A FIGURE-8 PATTERN AS SHOW

9 CHECK THE LIGHTS

READ THE INSTRUCTIONS IN THE MANUAL CAREFULLY.
WHEN PERFORMING INSTALLATION, ENSURE ELECTRICAL CONNECTIONS ARE SECURE AND CHECK THAT THE LIGHTS TURN ON.
AFTER COMPLETING THE INSTALLATION, CONFIRM THAT THE PROCESS HAS BEEN PROPERLY COMPLETED.