

SHAPE

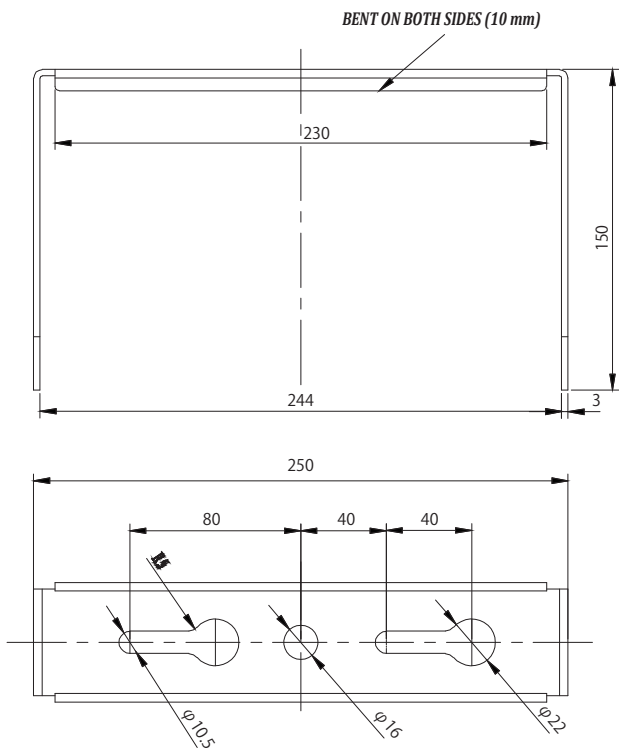

GENERAL VIEW

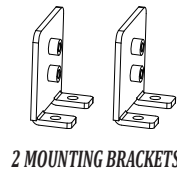
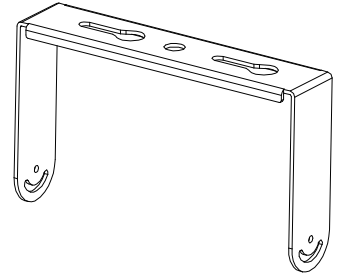

DRAWING (MAIN UNIT INSTALLED)

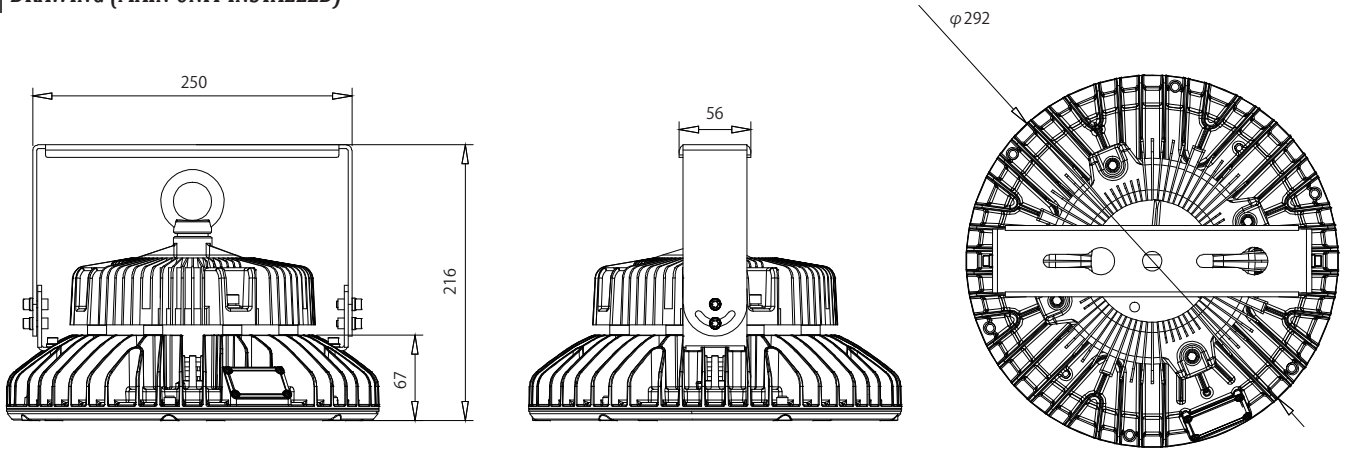

SPECIFICATION TABLE

MATERIAL	PLATE THICKNESS	COLOR	COATING	WEIGHT	ACCESSORIES
SPCC	3mm	Black	POWDER COATING	0.7kg	2 BRACKETS, 8 HEX SOCKET BOLTS FOR BRACKETS

SIZE A4	PRODUCT NAME U-SHAPED ARM FOR UN-C2 UN-C2-BR1	UN-C2-BR1-001	NIKKEN HARDWARE
		(Empty space)	